

QUALITROL-IRIS POWER, THE WORLD'S LARGEST PROVIDER OF ON-LINE PERIODIC AND CONTINUOUS PARTIAL DISCHARGE MEASUREMENT SYSTEMS

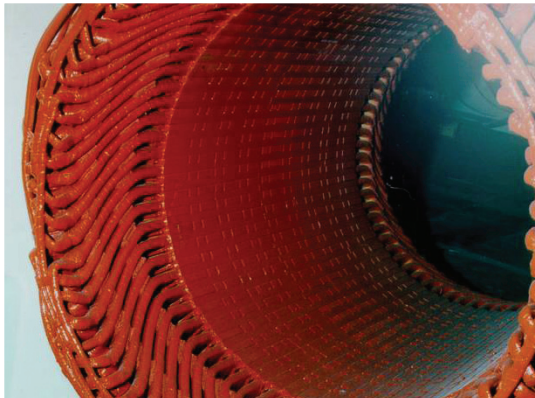

Iris Power BusTrac™

Continuous On-Line Partial Discharge Monitoring for Turbine Generators



IRIS POWER ON-LINE PRODUCTS

IRIS POWER BusTrac

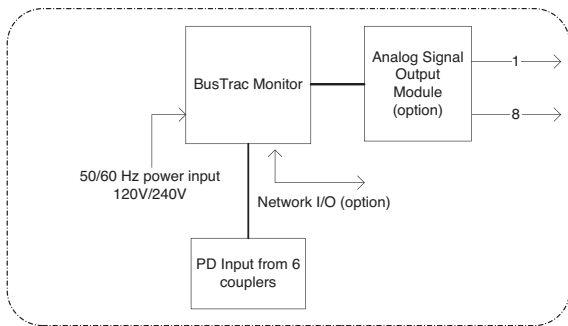

IRIS POWER BusTrac SYSTEM

The Iris Power BusTrac System consists of permanently installed capacitive couplers (2 per phase), a dedicated Iris Power BusTrac instrument, a system controller, plus digital communication to continuously monitor stator winding partial discharge (PD) activity.

Facilities that have existing bus coupler installations can easily install the Iris Power BusTrac monitor by connecting the instrument to the existing coupler termination panel. The install of the Iris Power BusTrac monitor does not require an outage. Qualitrol-Iris Power field service specialists can install and/or commission your Iris Power BusTrac instrument so that alarm trigger levels, and condition based measurement triggers, are set to the best levels for that particular machine.

The Iris Power BusTrac monitor offers a multitude of communication options. The monitor(s) can be wired via direct serial cable to the front panel RS232 connector. As an option, the Iris Power BusTrac can also be remotely accessed when wired with an RS485 (copper or fibre), or Ethernet via an external terminal server. For more information on other communication options, please contact your Qualitrol-Iris Power sales representative.

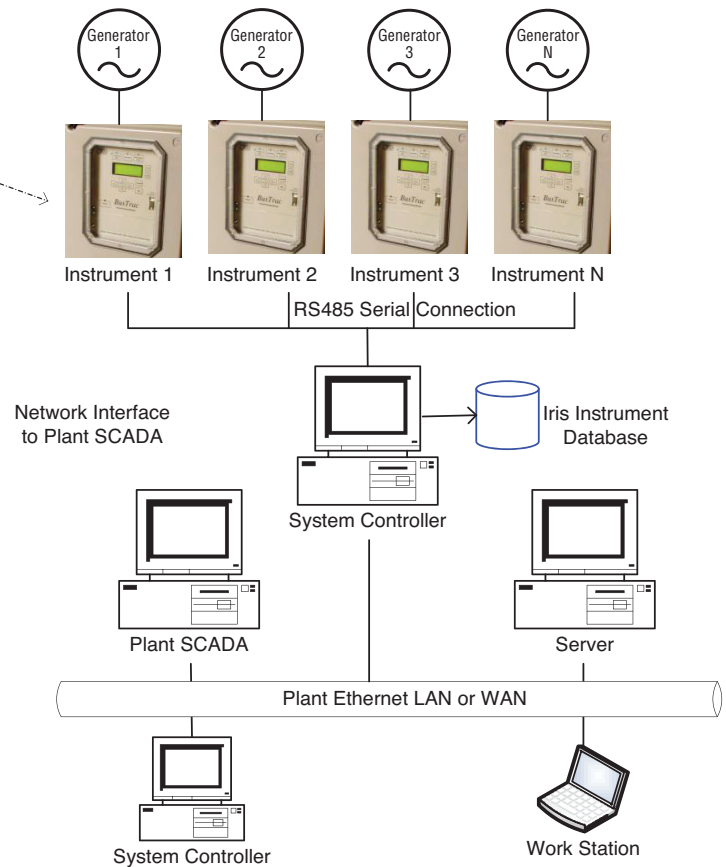

New users of the Iris Power BusTrac monitor technology must first permanently install 80pF capacitive couplers during a suitable machine outage.

The Iris Power BusTrac instrument is the product of Qualitrol-Iris Power's many years of experience developing on-line PD measuring systems for high voltage motors, turbine generators, and hydro generators. Like its predecessors, the Iris Power BusTrac monitor includes the unique methods specifically designed to overcome the electrical interference that is

typical of most power plant environments. This ensures reliable and repeatable test results with a low risk of false indications. The test data can be easily interpreted by maintenance professionals after participating in a two-day training seminar, offered by our experienced staff. Since the instrument is fully compatible with all previous generations of the Iris Power TGA-B technology, maintenance personnel can use the historical data to make a seamless comparison of similar machines.

IRIS POWER BusTrac

This assessment is enhanced through the use of the growing Iris Power database of over 225,000 test results.

The Iris Power BusTrac monitor is supplied with a termination panel that contains a multiplexor allowing the sequential monitoring of up to 6 pairs of couplers (up to 9 couplers in cross-compound generators). The instrument can be set up to run in one of two modes:

1. Controlled Mode:

The Iris Power BusTrac monitor is triggered either through the front panel keypad, or remotely (with networking option) using a host computer running the Iris Power TracCon™ controlling software. The test results can be viewed immediately and analyzed using Iris Power PDView™ display and trending software.

2. Autonomous Mode:

The Iris Power BusTrac monitor collects data continuously, several times an hour, and archives the



Installed Capacitive Coupler

Qm and NQN results which are important for trending and comparing similar motors or turbine generators. The data for the day and the month is summarized and archived for up to two years. It can be downloaded through a local RS232 port to a laptop computer or remotely (with networking option) using Iris Power TracLink™ software.

Although both modes are mutually exclusive, users can switch back and forth between them.

FEATURES

- Sophisticated monitoring and analysis system reduces false indications by digitally separating partial discharges from electrical noise, on a pulse-by-pulse basis.
- Proven filtering and pattern recognition enhances noise separation, allowing for a reliable and objective detection of poor impregnation, overheated windings, coil movement in the slot, ineffective or deteriorating grading/semi-conductive material problems and contamination.
- The system's compatibility with the Iris Power TGA-B™ technology allows users with existing sensor installations to commission the system without an additional outage. Data can be easily confirmed and further analyzed with Iris Power's TGA-B portable instrument.
- Ensures a consistent testing interval, thereby improving the quality of the trends. The alarm output permits maintenance personnel to focus on machines that exhibit unusual or high levels of partial discharge activity. This is attained by increasing testing frequency and by using the Controlled mode to generate plots that help to identify the prevailing failure mechanism of stator winding insulation.

BENEFITS OF CONTINUOUS MONITORING

Motors and generators have a performance record of being highly reliable. However, studies indicate that approximately 40% of all failures can be attributed to the gradual aging and deterioration of the stator winding insulation. On-line, periodic partial discharge testing has been successfully employed since 1951 in diagnosing accumulated winding-related problems in different types of generators.

Unlike periodic on-line PD testing, the Iris Power BusTrac monitor provides maintenance professionals with the opportunity to

- automate the measurement (on site or remotely)
- integrate the key trending parameters within the plant SCADA
- trigger a remote alarm indicating the need for a more detailed review of the collected data
- maximize collection of PD activity
- maximize warning of pending problems
- create a smoother trend curve
- lower testing cost.

The instrument uses the same sensors that have been permanently installed on motors and generators around the world over the last three decades and provides the reliability that comes with over 2000 installed continuous PD monitors.

IRIS POWER BusTrac

OPTIONS

- Analog Signal Output Module (ASOM): This option allows the Trac instrument to generate analog output signal levels, which are proportional to the NQN and Qm partial discharge summary numbers. These signals can then be fed into a plant acquisition system where they can be trended and stored. Utilizing this option allows the Trac instrument to be treated like any other field sensor and allows PD data display, alarming, and trending to be integrated with other plant monitoring systems under an interface familiar to plant personnel.
- Remote modes of communication permit command, control and configuration from a distance. For example, the key trending parameters can be transmitted to a SCADA system, and correlated with operating parameters such as turbo generator load and temperature for enhanced analysis of stator winding problems.
- Networking adds a RS485 port for remote communication to a remote computer using TracCon software.

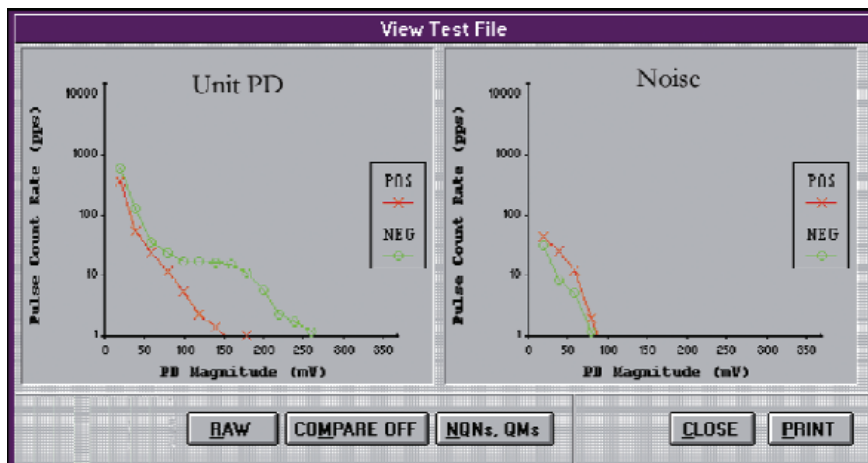

Iris Power BusTrac, Iris Power PDView, Iris Power TGA-B, Iris Power TracLink, Iris Power TracCon are Trademarks of Qualitrol-Iris Power.

Windows is a registered trademark of Microsoft Corporation in the United States and other countries.

WHAT IS PARTIAL DISCHARGE?

Partial discharges (PD) are small electrical sparks that occur within the high voltage electrical insulation in stator windings. PD occurs whenever there are small air gaps or voids in or on the surface of the insulation. Normally, well-made stator windings that are in good condition display very little PD activity. However, over 60 years' experience has shown that as a stator winding deteriorates from winding vibration, operation at high temperatures, or contamination from oil, moisture and other chemicals, the PD activity will increase by a factor of ten or more. Thus, on-line PD monitoring detects the main root causes of stator winding failure. Since PD monitoring can be performed during normal motor or generator operation, and generally gives two or more years of warning indicating a risk of failure, on-line PD monitoring has become a very powerful tool for predictive maintenance.

Some benefits of PD monitoring of the stator winding are:

- increased availability of machines
- plan maintenance based on actual conditions
- significant reduction of in-service failures

QUALITROL-IRIS POWER HAS BEEN THE WORLD LEADER IN MOTOR AND GENERATOR WINDING DIAGNOSTICS SINCE 1990, PROVIDING A FULL LINE OF ON-LINE AND OFF-LINE TOOLS, AS WELL AS COMMISSIONING AND CONSULTING SERVICES.



A QUALITROL Company

www.irispower.com

www.qualitrolcorp.com

Iris Power LP
3110 American Drive
Mississauga, ON, Canada L4V 1T2
Phone: 1-905-677-4824
Fax: 1-905-677-8498
sales.iris@qualitrolcorp.com

Qualitrol Company LLC
1385 Fairport Road
Fairport, NY, USA 14450
Phone (585) 586-1515
Fax (585) 377-0220



QUALITROL
Defining Reliability

Ver 6 • 08/10